

THE CORPORATION OF THE TOWN OF AMHERSTBURG

BY-LAW NO. 2005-11

Being a by-law to authorize the signing of an agreement
between Smith Contracting (o/a 1451237 Ontario Ltd.)
and the Corporation of the Town of Amherstburg

WHEREAS the Town of Amherstburg deems it desirable to construct soccer pitches,
access roads and parking lots at the Larry Bauer Sports Complex;

AND WHEREAS the Town of Amherstburg authorized Dillon Consulting Limited to
prepare tenders and complete the tender process;

AND WHEREAS Smith Contracting offered the low tender in the amount of
\$192,075.70;

AND WHEREAS Dillon Consulting Limited has prepared an agreement between the
Town of Amherstburg and Smith Contracting (o/a 1451237 Ontario Ltd.) and said
agreement is attached hereto as Schedule "A" and forms part of this By-law;

NOW THEREFORE THE COUNCIL OF THE CORPORATION

OF THE TOWN OF AMHERSTBURG HEREBY ENACTS AS FOLLOWS:

1. That the Mayor and Clerk be, and they are hereby authorized and instructed,
to execute the originals and the copies of the said agreement and to affix the
corporate seal thereto.
2. That this By-law shall come into force and take effect on the date of final
passage thereof.

Read a first, second and third time and finally passed this 24th day of January, 2005.

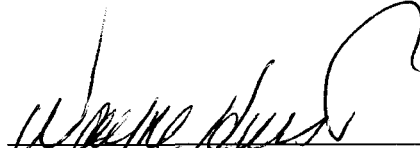

MAYOR

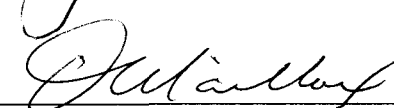

CLERK

Certified to be a true copy of By-law
No. 2005-11 passed by Council of the
Town of Amherstburg on the 24th
day of January, 2005.

Clerk

FORM OF AGREEMENT

THIS AGREEMENT made (in triplicate)

BETWEEN

Corporation of the Town of Amherstburg

hereinafter called the "OWNER"

Of the First Part

-and-

**Smith Contracting
(o/a 1451237 Ontario Limited)**

hereinafter called the "CONTRACTOR"

Of the Second Part

WHEREAS the Tender of the Contractor respecting the construction work, hereinafter referred to and described, was accepted by The Corporation of the Town of Amherstburg on the 29th day of November 2004.

THEREFORE THIS AGREEMENT WITNESSETH that in consideration of the premises and the covenants hereinafter contained, the Parties hereto agree as follows:

1. The Contractor hereby covenants and agrees to provide and supply at its expense, all and every kind of labour, machinery, equipment and materials for and to undertake and complete in strict accordance with its Tender dated the 12th of November, 2004 and the Contract Documents, including the Plans and Drawings and Specifications prepared by Dillon Consulting Limited and the Form of Tender which confirms the Total Tender Price and schedule for payment thereof, all of which said documents are annexed hereto and form part of this agreement to the same extent as if fully embodied herein, at and for the Total Tender Price of One Hundred and Ninety Two Thousand and Seventy Five Dollars and Seventy Cents (G.S.T. Included) (\$192,075.70).

2. The Contractor further covenants and agrees to undertake and complete the said work in a proper workmanlike manner under the supervision and direction and to the entire satisfaction of the Owner within the period of time specified in the said Tender.

3. The Contractor further covenants that it will at all times indemnify and save harmless the Owner, its officers, servants and agents, from and against all loss or damage, and from and against all actions, suits, claims and demands whatsoever which may be made or brought against the Owner, its officers, servants, and agents by reason or in consequence of the execution and performance or maintenance of the said work by the Contractor, its servants, agents or employees.

4. The Contractor further covenants and agrees to furnish in accordance with the above specifications a Performance Bond and a Labour and Material Payment Bond in the amount equivalent to one hundred percent (100%) of the Total Tender Price, in such form and issued by such surety as may be approved by the Owner's Solicitor, guaranteeing the faithful performance of the said work, in accordance with the terms of this agreement.

5. It is understood and agreed that the Contractor will not commence or proceed with the construction work herein before described or any part thereof, unless and until the Contractor has been instructed in writing to do so.

6. The Owner hereby covenants and agrees that if the said work shall be duly and properly executed and materials provided as aforesaid, and if the Contractor shall carry out, perform and observe all of the requirements and conditions of the agreement, the Owner will pay to the Contractor the Contract Price herein set forth in its Tender, such payment or payments to be made in accordance with the provisions of the Contract referred to above.

7. This agreement and everything herein contained shall ensure to the benefit of and be binding upon the Parties hereto, their successors and assigns, respectively.

IN WITNESS WHEREOF the Parties hereto have hereunto affixed their corporate seals duly attested by the hands of their proper Officers in that behalf, respectively.

SEAL

**THE CORPORATION OF THE
TOWN OF AMHERSTBURG**

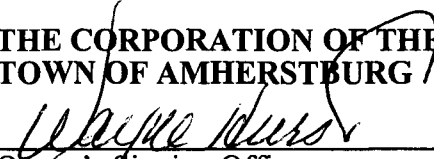

Owner's Signing Officer



Jan 28/05

DATE

SEAL

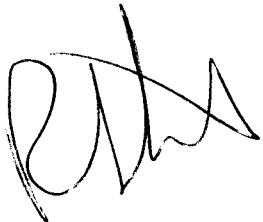



Contractor's Signature and Seal

Contractor's Signature and Seal

Smith Contracting (o/a 1451237 Ontario Limited)
Contractor's Name

5255 County Road No. 42
Windsor, Ontario N8N 2M1

Contractor's Address

Dec. 3/04

DATE

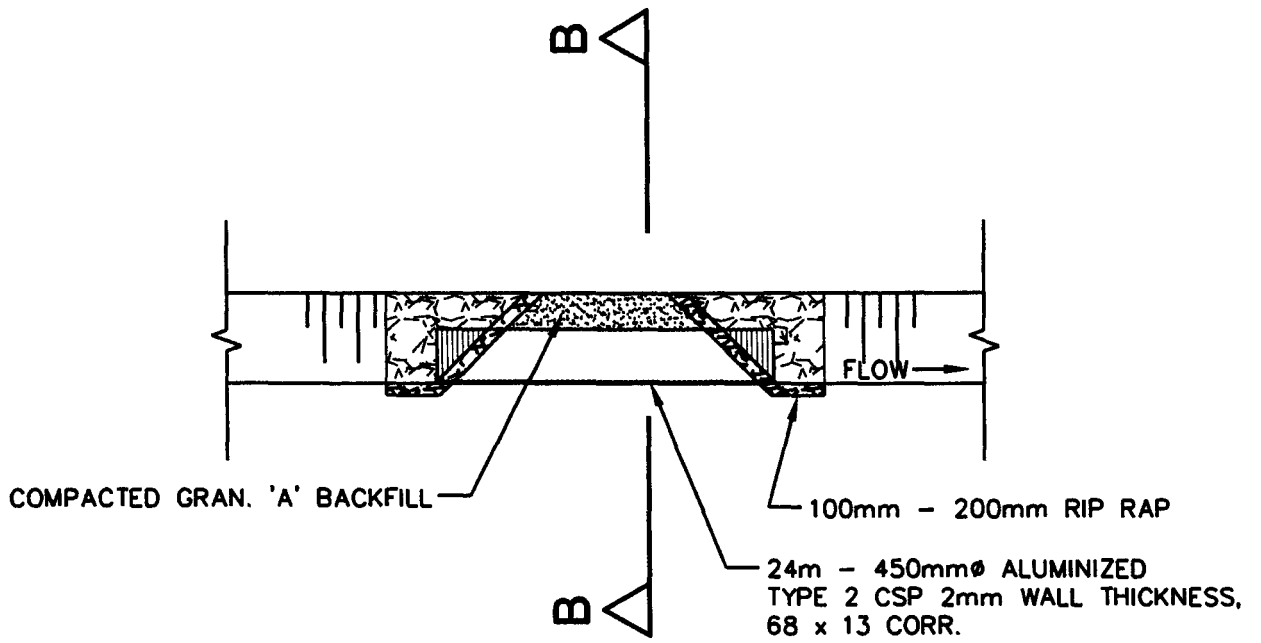

SECTION A-A

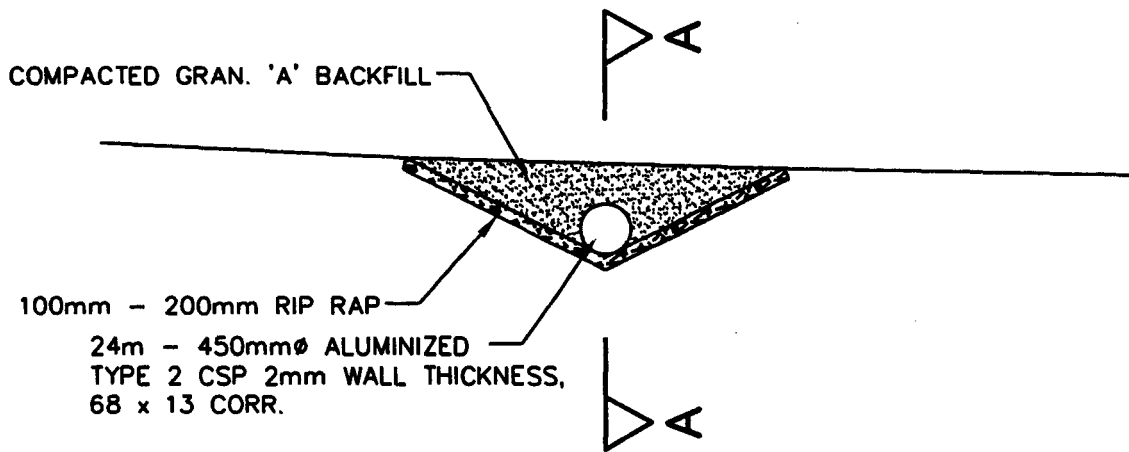

SECTION B-B

ACCESS CULVERT DETAIL

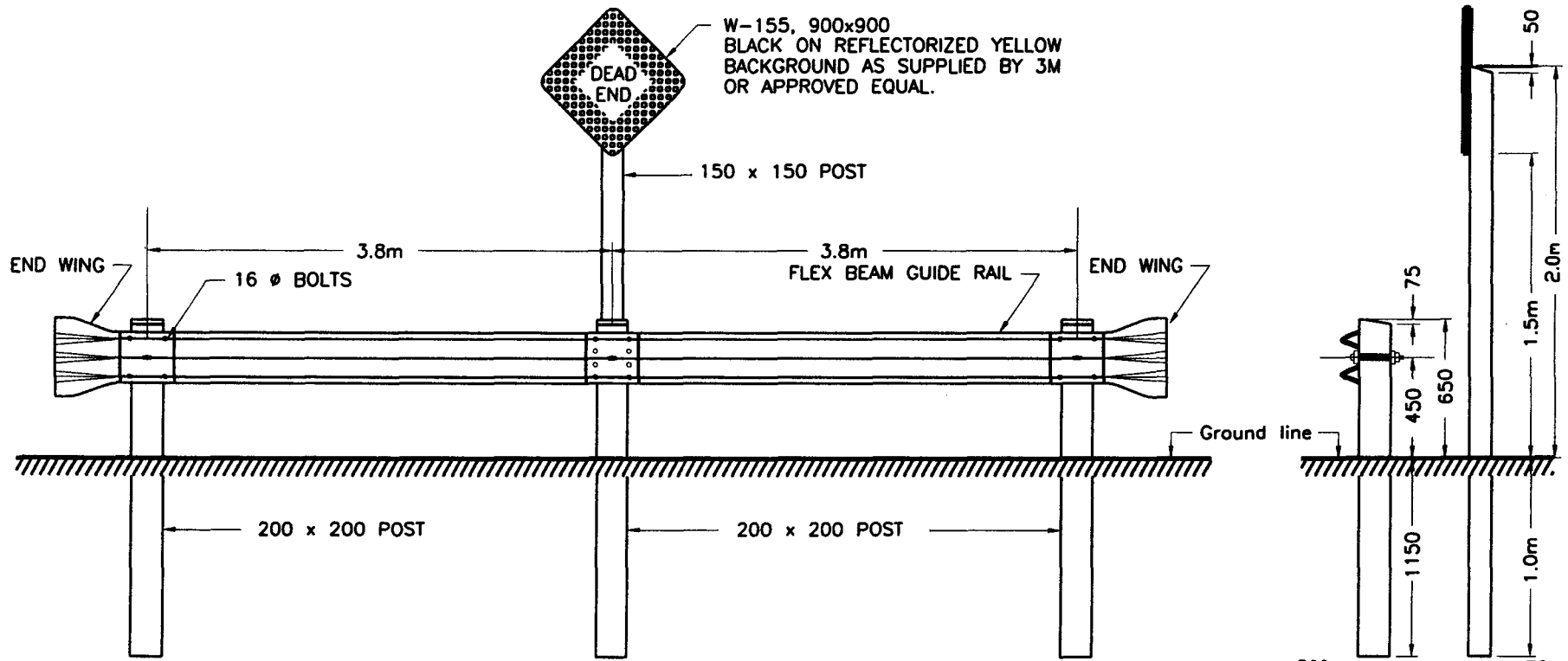

ELEVATION

SECTION

NOTES:

- (1) POSTS TO BE CREOSOTED BELOW GROUND LEVEL.
- (2) GUIDE RAIL AND POSTS TO BE PAINTED YELLOW (ABOVE GROUND) OVER AN APPROVED PRIMER.

DEAD END BARRICADE

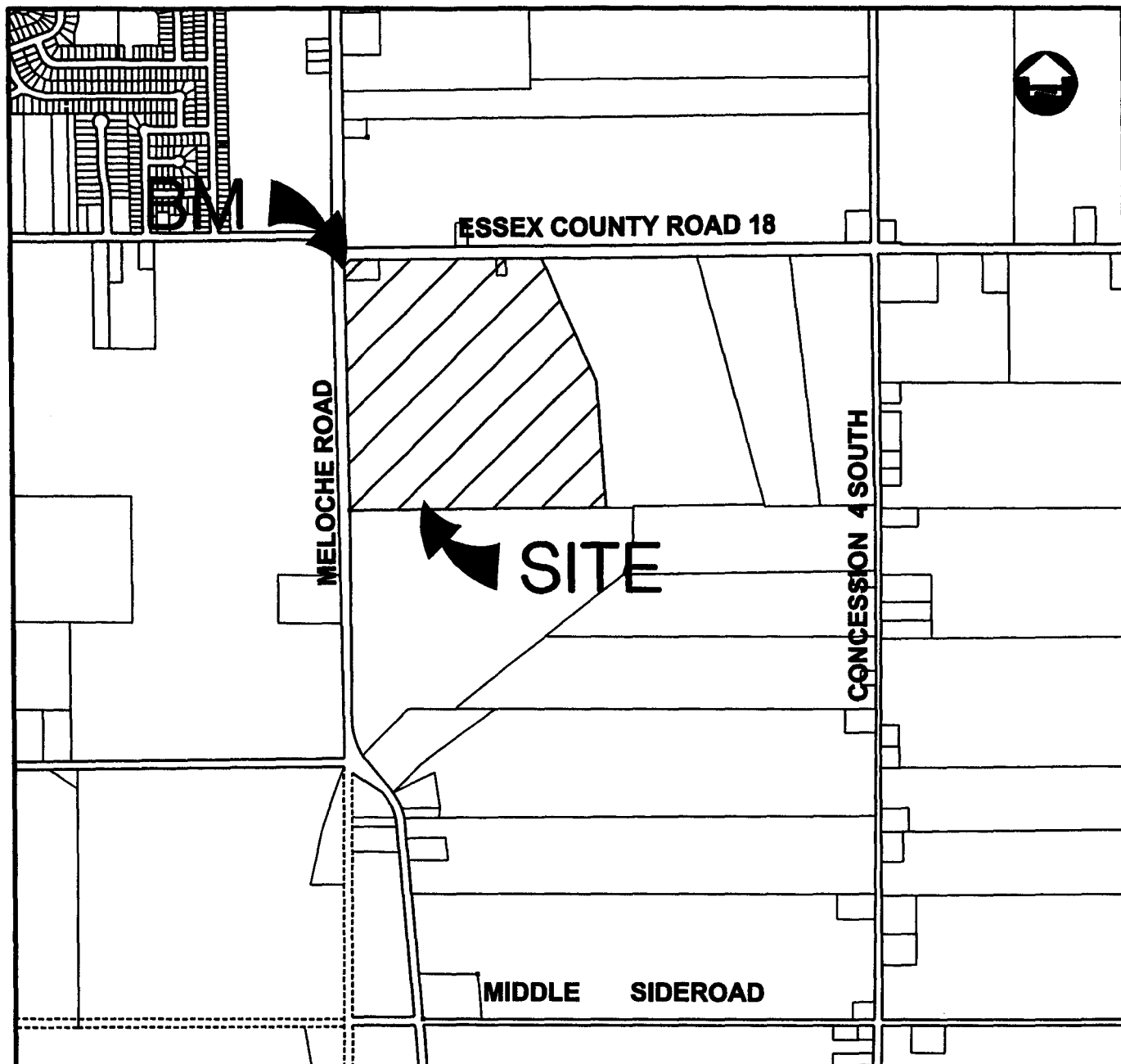

KEY PLAN

BENCH MARK

SITE BM
ELEV. 183.622m

TOP OF CONCRETE MONUMENT AT THE NORTH WEST
CORNER OF THE SITE NEAR THE INTERSECTION OF
SIMCOE STREET AND MELOCHE ROAD